

Heavy Duty 4-Pin Wiring Harness

Thank you for your purchase of this Diode Dynamics Wiring Harness. Using standard Deutsch DT style connectors, this harness is intended to be used with Stage Series pods with backlight functionality. Basic installation instructions are included below. Please contact us if you have any questions.

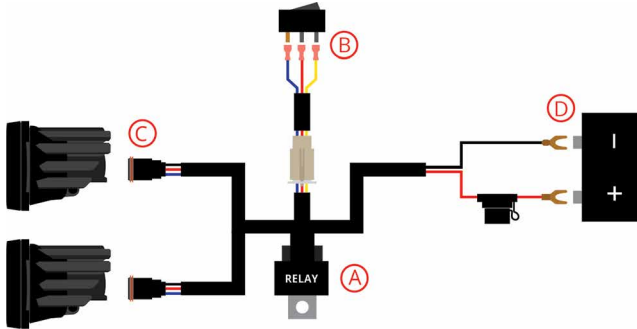

1. Determine a suitable location to mount the relay. (A) We recommend a location that is near the battery.
2. Determine a suitable location to mount the switch and route the switch to that location. This may require going through the vehicle's firewall. We recommend unplugging the toggle switch from the harness to route the wires more easily. Drill an appropriate-sized hole for the switch. Then reconnect the wires to the switch and mount it (B).
3. Connect the wiring harness to the pod (C). Next, route the harness to the battery. Be sure to avoid areas with excessive heat buildup or moving parts. We recommend following the path of the vehicle manufacturer's wiring harness.
4. Connect the split ring terminals on the wiring harness to the battery (D). The black (ground) wire should be connected to the negative battery terminal and the red (power) wire should be connected to the positive battery terminal.
5. Test thoroughly and aim the pod in the desired direction. **Please check your local laws and regulations for aiming, installation, and applicability.**

Please contact **Diode Dynamics** should you have any questions about the installation or wiring process, at **314-205-3033** (10a-5p CST) or **contact@diodedynamics.com**.

**100% SATISFACTION
GUARANTEE**

**3 YEAR
WARRANTY**



This installation guide is for the following SKU: DD4093 Heavy Duty Dual Output 3way 4p Wiring Harness

